



**JBS110**

For indoor/outdoor storage of chemical & spillage equipment, life jackets, gardening tools etc • Optional extras: Logo service available, plastic toggle (coding example: JBS110P).

Pour stockage intérieur/extérieur d'équipement chimique et de matériel d'essuyage, gilets de sauvetage, outils de jardin etc. • En option: Logo personnalisé sur demande, grenouillère plastique (par exemple: JBS110P).

für die Lagerung von Streugut, Chemikalienbinder, Rettungswesten, Gartengeräten, etc. im Innen-/Außenbereich • Extra: Kundenlogo, Kunststoffverschluss (Typenkennung: z. B. JBS110P).

Para el almacenamiento interior/exterio de equipo químico y residuos, chalecos salvavidas, herramientas de jardinería etc. • Extras opcionales: servicio de logotipo, precinto de plástico (ejemplo: JBS110P).



JBS110P-CORE

JBS110-COGR

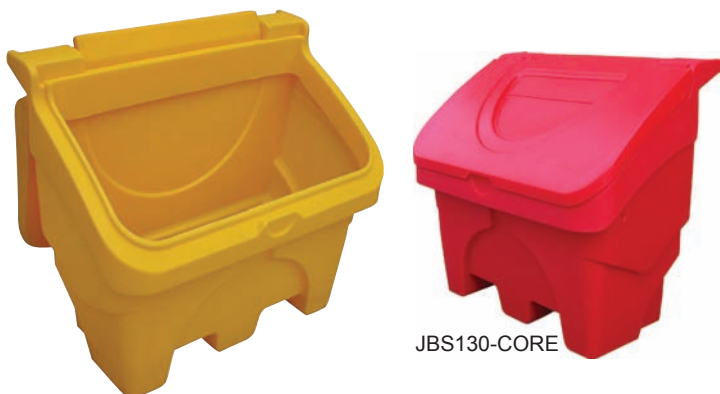

JBS200-COYE

JBS130-CORE

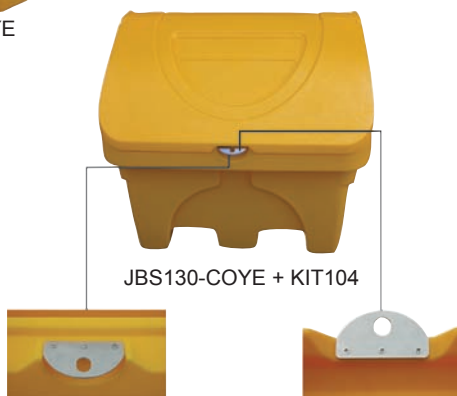

JBS130-COYE + KIT104

**JBS130 / JBS200**

For indoor/outdoor storage of chemical and spillage equipment • **Space saving, slim-line design, designed for wall placement** • Large opening for easy access • Forklift access • Stackable, for easy transportation • Optional Extras: Double logo facility, padlock facility (KIT104, padlock not included).

Pour stockage intérieur/extérieur de produits absorbants ou de tout autre matériel • **Design optimisé pour gain de place, à placer contre un mur** • Large ouverture pour pelletage aisé • Passage pour fourches de chariot élévateur • Emboîtable • En option: Personnalisation possible avec logo, Cadenassable (KIT104, cadenas non inclus).

für die Lagerung von Streugut, Chemikalienbinder, etc. im Innen-/Außenbereich • **platzsparendes, wandplatzierendes Design** • benutzerfreundlich • mit Stapler unterfahrbar • stapelbar für optimierten Transport • Extra: zwei Logopositionen, Verschlussinheit (KIT104, ohne Vorhängeschloß).

Para el almacenamiento interior/exterio productos químicos y equipamiento absorbente • **Diseño fino que ocupa poco espacio, Ideal para los cubetos situados contra el muro** • Fácil de acceso • Acceso para carretilla elevadora • Se puede apilar para facilitar su transporte • Extras opcionales: personalización posible con doble logo, Se puede cerrar con candado con KIT104. Candado excluido.





JBS400-COYE



JBS400-COGR



JBS400-COYE

## JBS400

For indoor/outdoor storage of chemical & spillage equipment, life jackets, gardening tools etc • Stackable • Angled lid allows water to run off • Forklift access • Plastic toggles and lynch pins as standard • Optional extra: Castors (KIT103).

Pour stockage intérieur/extérieur d'équipement chimique et de matériel d'essuyage, gilets de sauvetage, outils de jardin etc. • Emboîtable • Couvercle en pente pour drainer l'eau de pluie • Passage pour fourches de chariot élévateur • Goupilles de sécurité et grenouillères plastique avec chaque coffre • En option: roulettes (KIT103).

für die Lagerung von Streugut, Chemikalienbinder, Rettungswesten, Gartengeräten, etc. im Innen-/Außenbereich • übereinander stapelbar • abgewinkelter Deckel für Wasserablauf • mit Stapler unterfahrbar • Kunststoff-Verschlußbügel und -Sicherungssplint • Extras: Laufrollen (KIT103).

Para el almacenamiento interior/exterior de equipo químico y residuos, chalecos salvavidas, herramientas de jardinería etc. • Se puede apilar uno sobre otro • Tapa inclinada no permite una acumulación de agua • Acceso para carretilla elevadora • Pasador de seguridad, bisagra y cierre de plástico • Extras opcionales: KIT103.



JBS500-COYE



JBS500-COOR



JBS500-COYE + KIT103

## JBS500

Made from PE - 100% recyclable • **General storage box for chemical & spillage equipment, life jackets, gardening tools etc** • Forkliftable • User assembled lid • Angled lid allows water build up to run off • Cam lock, lid restraining straps & knob supplied as standard (KIT105) • Lockable with padlock (not supplied) • Nestable for easy transportation • 200 units per standard 20' container • Optional extra: Castors (KIT103) • **Available in International Orange for use as container for OPA 90 (Oil Pollution Act, USA) compliant marine spill kits.**

100% PE • 100% recyclable • **Pour stockage d'équipement chimique et de matériel d'essuyage, gilets de sauvetage, outils de jardin etc** • Manipulable avec un chariot élévateur • Couvercle assemblé par l'utilisateur • Le design du couvercle draine l'eau de pluie • Serrure batteuse, courroie de retenue du couvercle et poignée fournies (KIT105) • Cadenassable (non fourni) • Emboîtable pour réduire le coût de transport • 200 pièces par container 20' • En option: kit roulette (KIT103) • **Disponible en Orange International pour utilisation comme conteneur de kits d'absorption marine conformes à la norme OPA 90 (Oil Pollution Act, USA).**

aus PE - 100%ig recycelbar • **Universal-Staukasten für die Lagerung von Streugut, Chemikalienbinder, Rettungswesten, Gartengeräten, etc** • unterfahrbar • Deckel zur Selbstmontage • abgewinkelter Deckel für Wasserablauf • Verriegelung, Deckel-Haltebänder & Rundgriff als Standard (KIT105) • mit Vorhängeschloß abschließbar (Extra) • ineinander stellbar für optimierten Transport • 200 Einheiten/Standardcontainer (TEU) • Extra: Laufrollen (KIT103) • **in Leuchtorange (ähnlich RAL 2005) zur Aufbewahrung mariner Notfallkits gemäß OPA 90 (Oil Pollution Act, USA).**

Fabricado en polietileno (PE) 100% reciclable • **Caja de almacenamiento para el almacenamiento de equipo químico y residuos, chalecos salvavidas, herramientas de jardinería etc.** • Acceso para carretilla elevadora • Tapa a auto-ensamblar • Tapa inclinada no permite una acumulación de agua • Leva de fijación, cintas de soporte y tirador de serie (KIT105) • Se puede cerrar con candado (excluido) • Se puede apilar para facilitar su transporte y almacenamiento • 200 unidades por contenedor de 20' • Extras opcionales-Ruedas (KIT103) • **Disponible en color naranja internacional por uso como contenedor para los absorbentes para usar en medio marino en conformidad con la ley OPA90 (Oil Pollution Act, U.S.A).**





JBS110-COGR



JBS130



JBS200-COYE



JBS400R-COYE



JBS400-COYE



JBS500-COOR



	 mm	 mm	 mm	 kg			A / B mm
JBS110-COYE	570	650	500	8		110	-
JBS130-COYE	750	850	500	12		130	145 / 465
JBS200-COYE	855	1005	590	16.5		200	
JBS400-COYE	790	1200	600	18		400	200 / 800
JBS400R-COYE	855	1000	755	20.5		400	170 / 440
JBS500-COYE	920	1265	850	25.5		500	190 / 660
JBS500-COOR							

Other colours available on request / Autres couleurs disponibles sur demande / andere Farben auf Anfrage / Otros colores disponibles



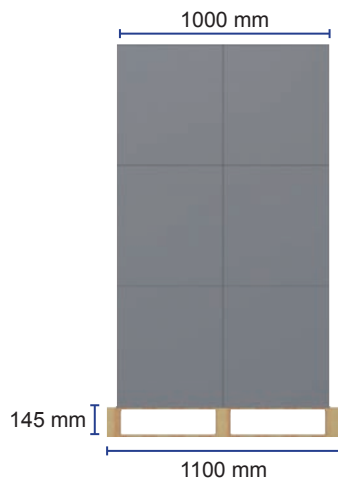
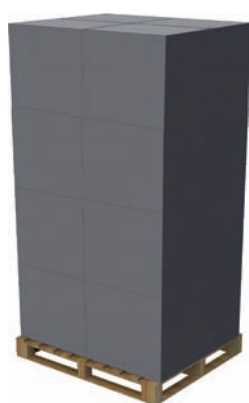

**JBS110**  
 16 units per pallet  
 16 pièces par palette  
 16 Teile pro Palette  
 16 piezas por palé

**JBS130**  
 8 units per pallet  
 8 pièces par palette  
 8 Teile pro Palette  
 8 piezas por palé



**JBS200**  
 6 units per pallet  
 6 pièces par palette  
 6 Teile pro Palette  
 6 piezas por palé

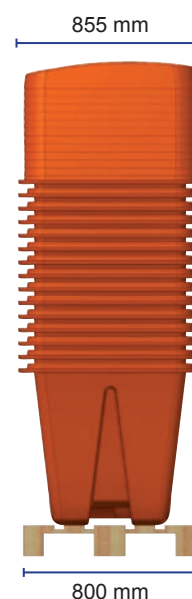
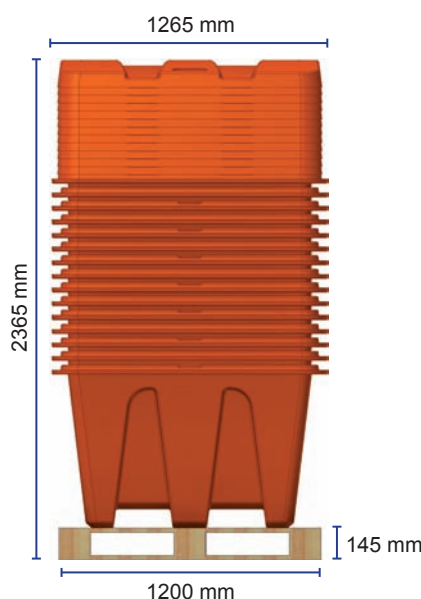
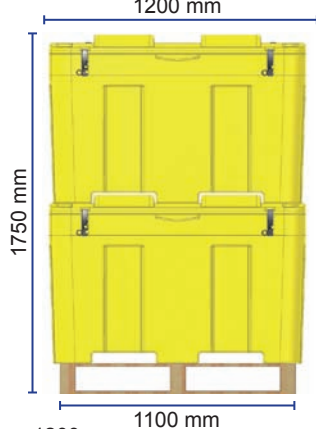
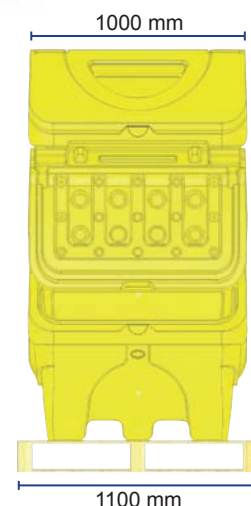
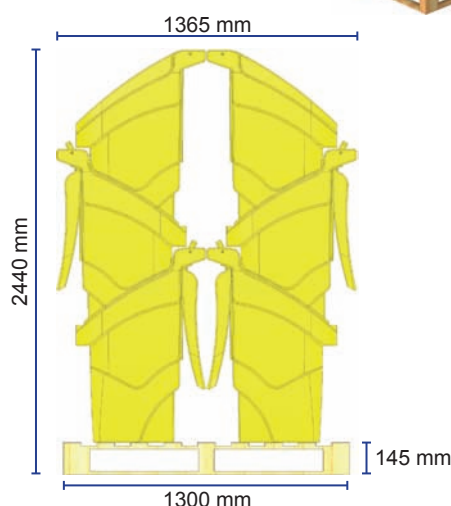
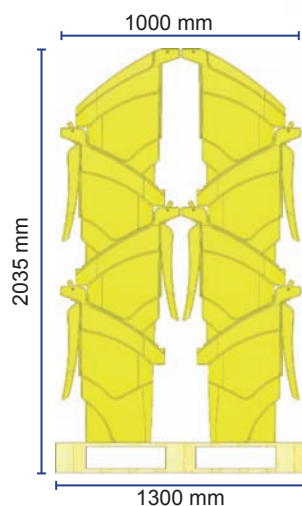
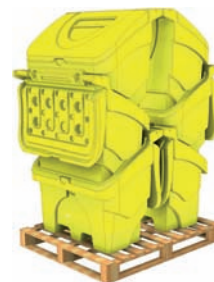

**JBS400**  
 4 units per pallet  
 4 pièces par palette  
 4 Teile pro Palette  
 4 piezas por palé



**JBS500**  
 15 units per pallet  
 15 pièces par palette  
 15 Teile pro Palette  
 15 piezas por palé